

DURASLOT® Surface Drains



**Durable, economical, corrosion-resistant
collection of surface runoff**



A sensible alternative to metal and concrete

Since 1987, DURASLOT® surface drains have been providing reliable storm water collection in applications ranging from residential driveways to multi-lane super highways.

The product is made from double-wall corrugated polyethylene pipe with an aluminum slot mounted on top. It is designed to intercept sheet flows across paved or cleared areas, or as it collects in low spots. It is a cost-effective substitute for corrugated steel slotted drains, precast trench drains, or cast-in-place trench drains with steel or cast iron grates.

DURASLOT drains use N-12® pipe, manufactured by Advanced Drainage Systems. An outer corrugated wall provides strength and durability, while the smooth interior lining gives exceptional hydraulics. ADS is the exclusive sales agent for DURASLOT drains.

Physical details

- **Slot height:**
 - 2 1/2" for residential and pedestrian areas
 - 6" for H-25 loading in vehicular traffic areas
 - Taller slots are available on special order
 - Variable height slot to provide slope in the pipe invert at level grade (special order)



Standard grate (left) for areas with both vehicular and pedestrian traffic. Open grate (right) only for areas with no pedestrian traffic.

- **Pipe length:** 10 feet
- **Pipe diameter:** 4" through 36"
- **Slot opening:**
 - 1 1/4" wide in 4" diameter
 - 1 3/4" wide in 6" diameter and higher
- **Grate options:**
 - 1/2 - #13 galvanized steel (stock standard)
 - Open top without grate (available standard)
 - Other types of grating available on special order

• **Grate Connector.** Joins the grates at the ends of the slots, and can be easily removed to allow a hose to flush out the pipeline.

• **Pipe Adapter.** Connects DURASLOT drain to N-12 pipe. A corrugated pipe coupler that is modified to accept DURASLOT drain on one end and N-12 pipe on the other. A Grate Anchor is included (see below).

• **End Cap.** Modified to close the upstream end of DURASLOT drain. A Grate Anchor is included (see below).

• **Grate Anchor.** Used at the end of each DURASLOT run to close off the end of the slot, anchor the end of the grate into the concrete or asphalt surrounding the slot, and keep the grate in tension for added strength.

System components

• **Coupler Band.** Connects DURASLOT drain to DURASLOT drain. A modified N-12 band with angles extended up is used to clamp together the ends of the two slots being joined. A thumbscrew and wingnut fasten the band angles onto the ends of the slots. A Grate Connector is included (see below).

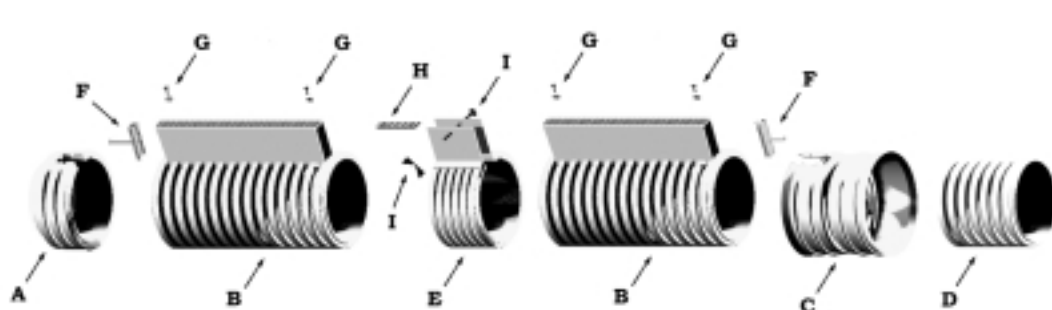

- A - End Cap
- B - DURASLOT drain
- C - Pipe Adapter
- E - Coupler Band
- F - Grate Anchor
- G - 1/4" SPH Screw with Washer
- H - Grate Connector
- I - 5/16" Thumbscrew with Wingnut

Applications

DURASLOT drains are linear drains designed to capture sheet flow of water from sloping paved surfaces or cleared areas. They have the same inlet as corrugated steel pipe slotted drains. A 1 3/4" wide opening runs the length of the pipe, and special connectors provide for a continuous slot of virtually unlimited length. For curb and gutter applications, the inlet acts as an orifice, and the AISI Handbook* method can be used to determine hydraulic capacity.

For interception of sheet flow, the inlet acts as a weir. Testing done by the FWHA concluded that for inlets as narrow as one inch wide virtually all of a flow of 0.04 cfs per foot of inlet could be intercepted under most design conditions. Testing commissioned by the manufacturer confirmed this, and also developed "rule of thumb" capacities for 1 3/4" wide slots with and without grating:

1 3/4" open top slot => .065 cfs per foot of inlet

1 3/4" slot with grate => .046 cfs per foot of inlet

Typical applications for DURASLOT drains include the following:

- Roadways
- Sidewalks
- Parking lots
- Plazas
- Loading docks
- Industrial floors
- Parks and athletic fields

* American Iron and Steel Institute Handbook of Steel Drainage and Highway Construction Products, 1994, pages 218-223, "Hydraulics of Storm Water Inlets"



Concrete floors



Residential driveways



Water treatment plant- corrosion resistance is critical.



Against roadway curbs, berms and medians



Commercial parking lots



Loading docks and maintenance facilities

Fabricated Fittings

Design flexibility is enhanced with a complete line of fabricated fittings in all standard pipe sizes. Styles include elbows in virtually any angle up to 90°, tees, wyes, reducing tees, and other fittings custom fabricated to your specifications.



Competitive Benefits

DURASLOT surface drains offer a number of cost and performance benefits compared to corrugated metal, polymer trench drain and cast-in-place systems:

- **Corrosion-resistant** polyethylene and aluminum construction is impervious to soil acids, storm water contaminants, and road salt.
- **Greater hydraulic efficiency.** The flow in smooth inner wall N-12 pipe is superior to corrugated steel pipe.
- **Lower installation costs.** Lightweight sections set in place quickly and easily with no heavy machinery or extra manpower.
- **Material cost is less** than other systems which can support vehicular traffic.
- **Long ten-foot lengths** versus the short one meter lengths of polymer trench drain. Speeds installation time and makes it much easier to maintain a flat or constant slope invert.
- **Impact-resistant** polyethylene withstands bumps during shipment, storage and handling. No waste due to deformation or breakage.



Heavy equipment is not required to set DURASLOT drains in place. Long, lightweight sections and easy-to-use coupler bands cut installation time significantly.



Smooth inner wall N-12 pipe resists chemical attack and provides superior hydraulic flow compared to corrugated steel pipe.

Variable Height Slot

In addition to the standard fixed slot height style, DURASLOT drains are available with a variable height slot to permit slope in the pipe invert when grade is level. The standard change in slot height is 5/8" per 10-ft. length (H_2 minus H_1 in drawing) nominally a 1/2% slope. Other slopes are also available. The product is delivered in sequentially numbered sections. Slot heights of more than 30" have been installed. Contact ADS for complete product and installation details.

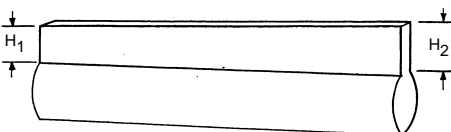

Variable height slot DURASLOT drains can be ordered in sequentially numbered sections with maximum slot heights exceeding 30".

Specifications and Dimensions

Product Specification

DURASLOT Surface Drains shall be manufactured from corrugated polyethylene pipe with a smooth inner wall, with pipe and fittings conforming to AASHTO M252 and/or M294. A grate frame that forms a slot shall be mounted in the pipe so as to provide a linear inlet into the top of the pipe to collect surface runoff. The slot shall be manufactured from .063 tempered commercial aluminum and shall have two parallel plates separated by vertical spacers spanning the slot on 6" centers. The grating within the slot opening shall be 1/2 - #13 galvanized steel. The slot shall be coated with a primer to protect the aluminum when installed in concrete. The flange at the bottom of the slot shall be riveted to the pipe with a minimum of two rivets per linear foot. The pipe shall have a section removed to accept the slot so as to maintain the original diameter, providing ease in transition to conventional systems. Sizes and dimensions shall conform to the information on the DURASLOT Physical Dimensions table below for the pipe diameter and slot height specified.

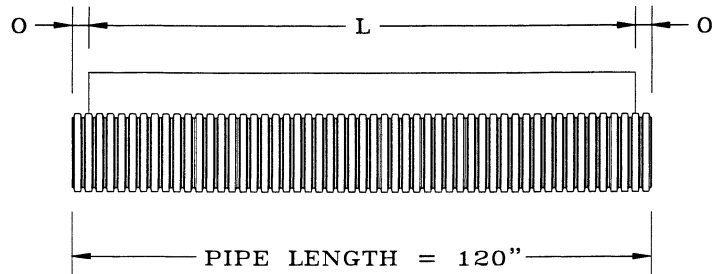

Pipe Diameter (inches)	O	L
4, 6, 8	1"	118"
10, 12, 15, 18, 24, 30, 36	2"	116"

Physical Dimensions

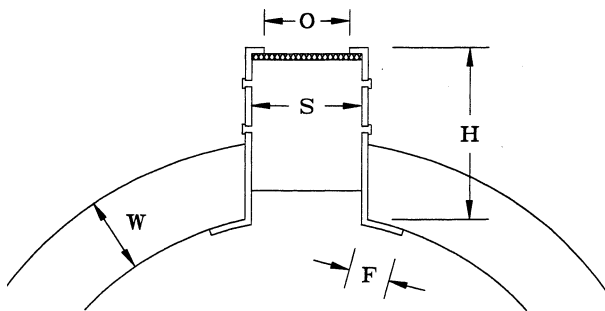

2 1/2" Slot shown with 1/2 - #13 Galvanized Grating

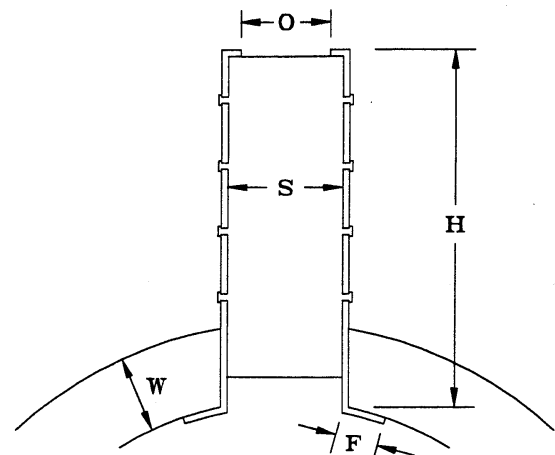

6" Slot shown without Grating (Open Top)

	Pipe Diameter									
	4"	6"	8"	10"	12"	15"	18"	24"	30"	36"
H (2 1/2" slot)	2 3/4" *	3" *	3" *	3"	3 1/2" *	3 1/2"	3 1/2"	3 3/4"	4 3/4"	4 3/4"
H (6" slot)	N/A	6 1/2" *	6 1/2" *	6 1/2"	7" *	7" *	7" *	7 1/4"	8 1/4"	8 1/4"
W	.34"	.46"	.60"	.73"	1.15"	1.30"	1.56"	1.86"	2.93"	3.13"
F	1/2"	3/4"	3/4"	3/4"	3/4"	3/4"	3/4"	1"	1"	1"
O	1 1/4"	1 3/4"	1 3/4"	1 3/4"	1 3/4"	1 3/4"	1 3/4"	1 3/4"	1 3/4"	1 3/4"
S	1 3/4"	2 1/4"	2 1/4"	2 1/4"	2 1/4"	2 1/4"	2 1/4"	2 1/4"	2 1/4"	2 1/4"

* In-stock standard sizes

Installation Basics

DURASLOT surface drains are made from a flexible conduit which is designed to attain its structural strength utilizing ring compression derived from soil pressure. For this to occur, a minimum cover height of 12" is typically required with N-12 pipe. This cannot be achieved with DURASLOT drains because the tops of the 2 1/2" or 6" slots must be set at grade. Therefore, the drain must be backfilled with a certain amount of concrete to support the pipe and provide a non-eroding surface at the top of the slot where water enters the inlet.

The depth of concrete backfill depends on the traffic load over the DURASLOT drain installation:

- **Heavy traffic.** Completely surrounded by concrete for critical loading applications such as frequent

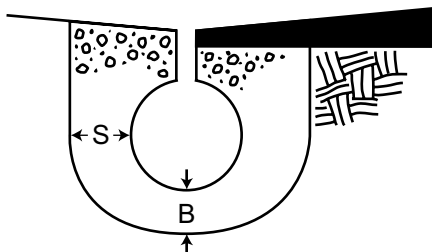

H-25 traffic on a highway. The S and B dimensions are typically 3" to 6" depending on specific project conditions (design layout, traffic patterns, soil properties, etc.).

- **Moderate traffic.** Surrounded by concrete to below the center of the pipe. Used where vehicular traffic is

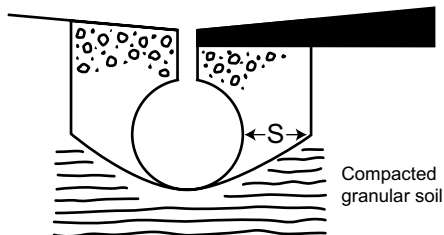

moderate (retail parking lots, driveways, against curbs, etc.),

- **Residential/pedestrian traffic.** Concrete, asphalt, or soil concrete slab at grade for non-vehicular

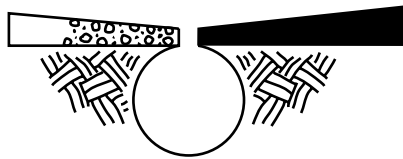

installations (patios, sidewalks, against foundations, landscaping projects, etc.).

Installation Notes

1. DURASLOT drains may be set and secured in place using one of the following methods:

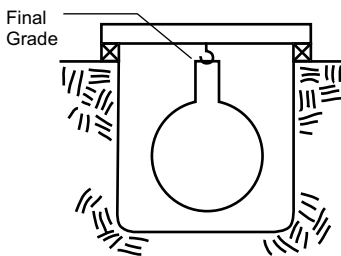

a. Hung from cross members on grade

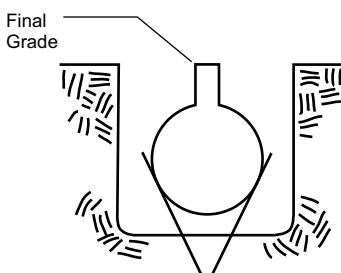

b. Set in a cradle made of rebar or wood

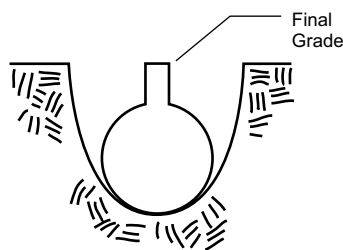

c. Set in the trench bottom (not for H-25 loading)

2. Cover the slot opening to prevent clogging with poured concrete or asphalt. The easiest way to protect the slot is to cover it with 2" duct tape. An alternate method is to place a 2 x 4 on the 2" edge on top of the slot.

3. When pouring concrete around DURASLOT drains, especially when

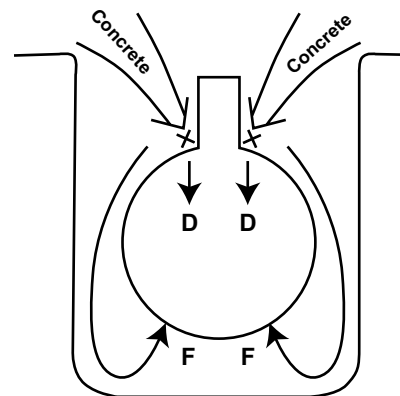

the pipe is sitting in a cradle, pour down on the spot where the slot meets the pipe (X), taking care to keep the slot upright. This will provide some downward force (D) that will keep the pipe from rising due to upward force (F) as the concrete fills the trench.

4. Recess. The top of the slot opening should always be set 1/8" to 1/4" below finished grade. This allows surface runoff to enter the inlet efficiently and protects the grate and flanges from snowplows and the like. A mason's tool can be used to round the edge after the protective tape or 2 x 4 is removed from the slot opening.

5. DURASLOT drains are designed as a system, and it is important that all fittings and hardware are used during installation. Grate connectors and anchors keep the grate in tension and tie the ends of the grate into the concrete or asphalt. Anchors and end caps or adapters should always be used at the end of a run. Use only DURASLOT coupler bands to join sections of DURASLOT drain (see page 2).

Case Histories

Interstate Highway Median

For a construction project on I-87 in Westchester County, New York, a total of about two miles of drainage lines were required for the temporary crossovers in the highway median. In the past, corrugated metal slot drain had always been specified for this type of project, but in this instance, Duraslot was accepted as a substitute.

New York DOT and Thruway Authority officials were persuaded that DURASLOT drains could not only provide the same structural strength as metal, but the plastic pipe's superior hydraulics would create better flow in this extremely flat terrain. The installing contractors appreciated the product's lighter weight, and the easier and safer methods of connecting the sections together.



More than 11,000 ft. of 15" DURASLOT drains were installed on the project. Contractors estimated that installation time was reduced by at least 20%, saving not only project costs, but also the time traffic would be backed up due to crossover construction.

Pedestrian Parkway

The city of Pembroke Pines, Florida, was building a large new park with several athletic fields. Drainage was required in the areas of heavy pedestrian traffic, and corrugated metal slotted drain was originally specified for this purpose.

After learning of the strength, superior flow, and corrosion resistance of the plastic alternative, the engineer changed not only the surface drain specification to DURASLOT, but also the remainder of underground drainage to ADS N-12 pipe and Nyloplast® catch basins.



A total of 1,540 ft. of DURASLOT 12" drain with a 2 1/2" slot height were installed. Because no vehicular traffic was involved, stone backfill could be used up to the springline of the pipe, with concrete installed to finished grade.

Entrance Boulevard

One of the first right-of-way plastic pipe installations allowed by the city of Chula Vista, California, occurred on the entrance to the West Coast Olympic Training Facility in that city.

Traditionally, bituminous-coated steel slot drain was specified for municipal roadways, but engineers for this project decided to give DURASLOT drains a try. More than 1,000 ft. of 18" DURASLOT drain were installed at the curb to collect sheet flow from a long sloping curve in the entrance boulevard.

The contractor was extremely pleased with the product, reporting that it cost slightly less than metal, and was lighter in weight and much cleaner to handle than the coated steel. Delivery time for DURASLOT drains was noticeably quicker than for the metal pipe, as was installation time, due to the ease with which the plastic could be cut, set in place, and clamped together.



The world leader in plastic drainage

DURASLOT drains are part of a complete line of drainage system components offered by ADS, the world's largest manufacturer of corrugated high density polyethylene pipe. From a single source, designers can specify pipe and fittings from 4" through 60" diameters, engineered water quality units, Nyloplast® drain basins and structures, and a broad line of geotextiles and erosion control products.

For information or technical assistance, including a CD-ROM with complete DURASLOT drain design data, contact your local ADS representative or call 1-800-821-6710. Standard details and CAD drawings are also available on the ADS Web site, www.ads-pipe.com.

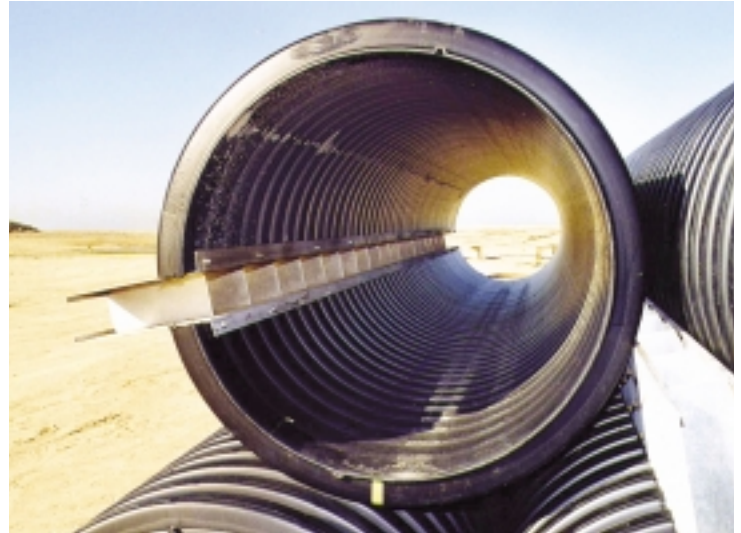

ADS Sales and Service Locations

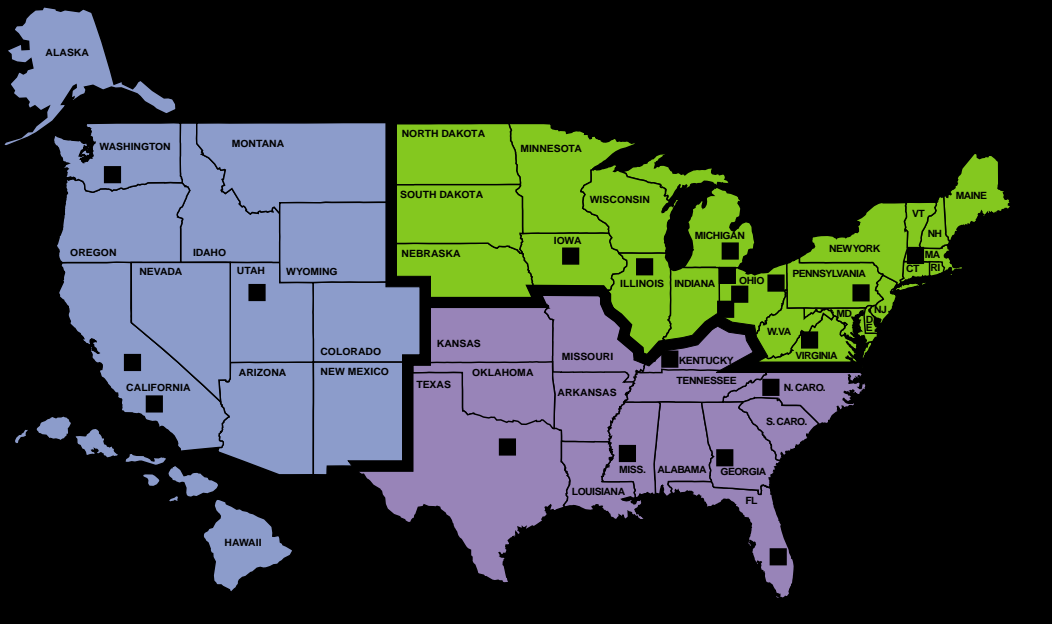

To learn more about Duraslot surface drains, and the complete line of ADS drainage products, log on to www.ads-pipe.com, or call 1-800-821-6710.

Zone Offices

- MIDWEST/NORTHEAST
LONDON, OH
1-800-733-9554
- SOUTHERN
FRANKLIN, TN
1-800-733-9987
- WESTERN
WASHOUGAL, WA
1-800-733-8523
- MANUFACTURING
FACILITY
LOCATIONS



**THE MOST
ADVANCED
NAME IN
DRAINAGE
SYSTEMS®**



ADVANCED DRAINAGE SYSTEMS, INC.

4640 TRUEMAN BLVD., HILLIARD, OH 43026

800-821-6710 www.ads-pipe.com

© 2003 Advanced Drainage Systems, Inc.

® Duraslot is a registered trademark of Hall Construction Products and Services.

® The Green Stripe is registered in the U.S. Patent and Trademark Office.